

Made in India  
Quality Products Since 1963

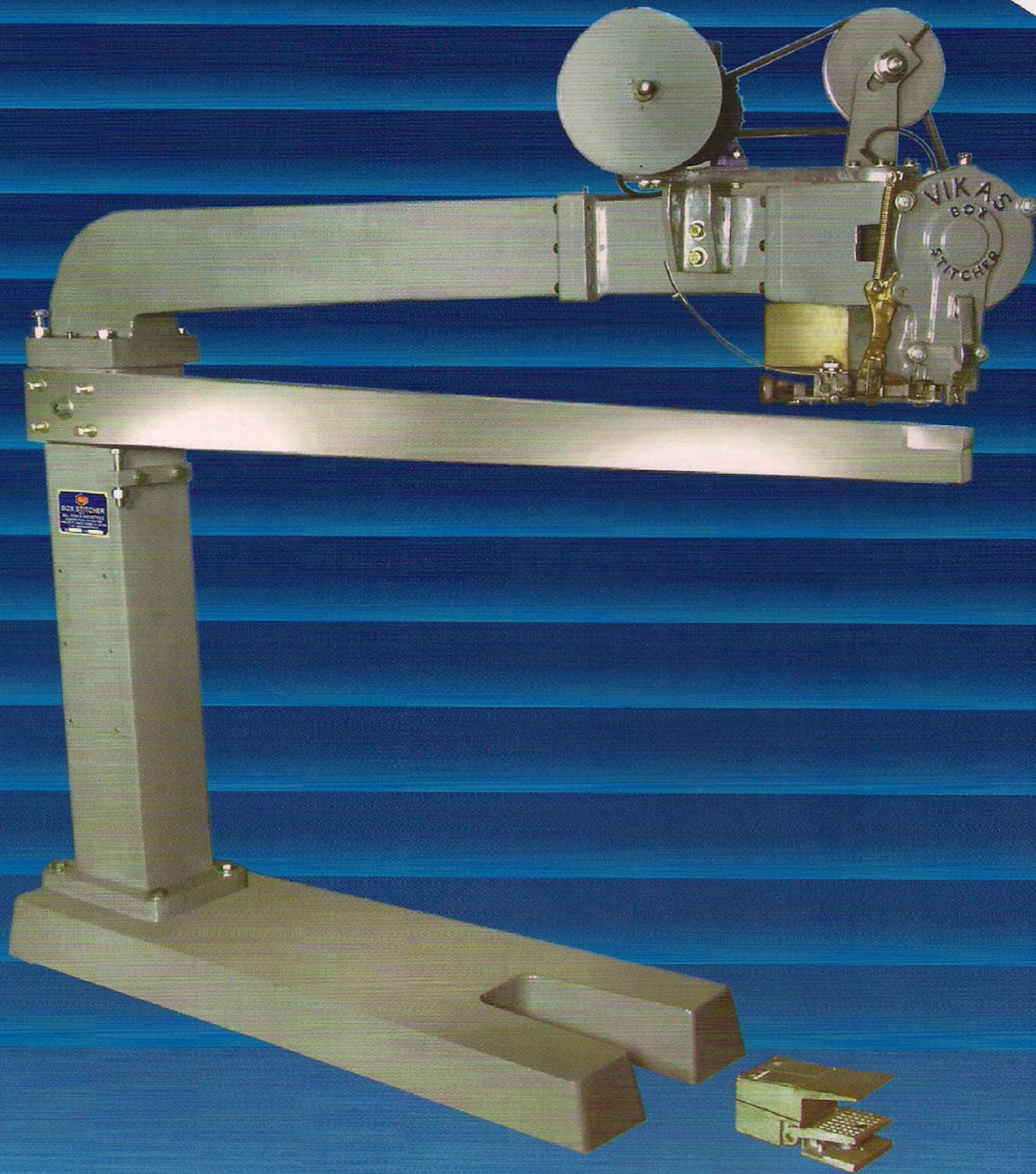

# 45° ANGULAR SHAFT LESS SINGLE PIN BOX STITCHER



# 45° ANGULAR SHAFT LESS SINGLE PIN BOX STITCHER

## FEATURES WHICH MAKE **VIKAS** ANGULAR STITCHER UNIQUE & PRECISE.

- The Machine is equipped with Electromagnetic Clutch instead of Mechanical Clutch.
- The machine is not equipped with shaft, Bevel gears and clutch spring, thereby reducing maintenance.
- All parts are interchangeable and easily available.
- Simple adjustment of arm height to suit thickness
- Sturdy machine that give years of efficient service at negligible up keep cost.
- Single rotary cam controlling full stitching cycle including wire cut off.
- Parts are made of best steel and designed to give the longest possible life and easy maintenance.

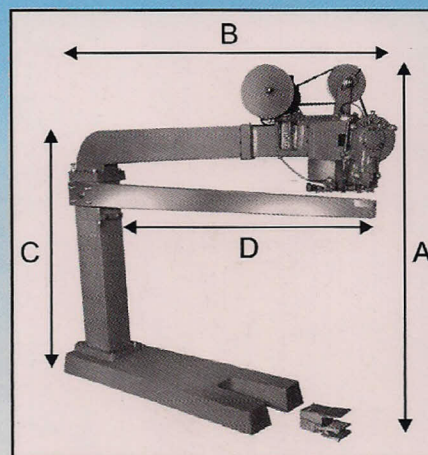
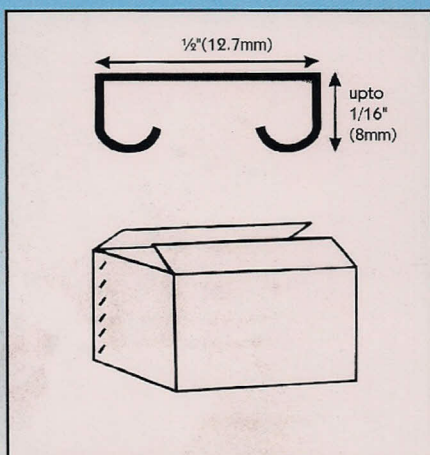

## SPECIFICATIONS

Arm Length	52"(1320mm)	66"(1680mm)	72" (1830mm)
Stitch Size	12.7mm	12.7mm	12.7mm
Capacity	1.6mm to 8mm	1.6mm to 8mm	1.6 to 8mm
Driving Pulley	6" Dia A Type V Belt	6" Dia A Type V Belt	6" Dia A type V Belt
Speed (App.)	325 stitches/min.	325 stitches/min.	325 stitches/min.
Electric Motor	½ HP 1440 RPM	½ HP 1440 RPM	½ HP 1440 RPM
Size of wire size	12/25 Swg Flat Wire	12/25 Swg Flat Wire	12/25 Swg Flat Wire
App.Net.wt. (Kg.)	525	575	625
App.Gross Wt.	675	725	775
A (mm)	1840	1840	1840
B (mm)	1830	2030	2235
C (mm)	1480	1480	1480
D (mm)	1320	1680	1830

\* Modifications reserved, specifications not binding.

Manufactured by :

### **VENUS INDUSTRIES**

B-6, Phase-II, Mayapuri Industrial Area, New Delhi-110064

Phone : 91-11-28111321/41694162, Fax.: 91-11-28114543

Mobile: 9312262807

E-mail:info@vikasboxstitchers.com

E-mail:damandeep1@yahoo.com

Website:www.vikasboxstitchers.com